

STRONGWALL BARRICADES

ADA Compliant pedestrian barricades

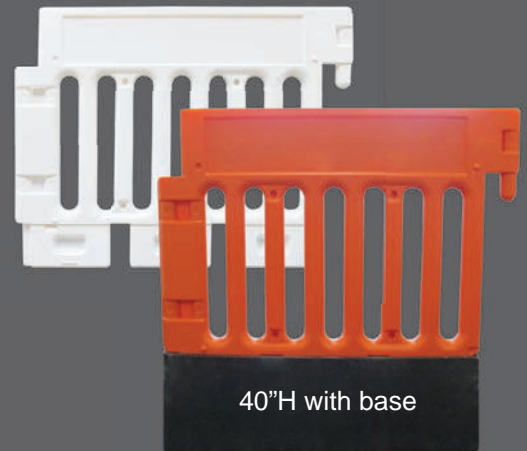

Create a temporary pedestrian walkway



40"H with base

**STRONGWALL
ADA PEDESTRIAN BARRICADE**

INTERCHANGEABLE BASE

Use with both Strongwall styles



**43 lb. Base
Eliminates
Sandbags**

Base

- ADA Compliant, no trip hazard for pedestrians
 - meets or exceeds ADA Guidelines and MUTCD Standards
- No sandbags needed!
- Linking sections are made up of two pieces that securely fit together
 - Top Wall - rugged polyethylene
 - Bottom Base - 43 lb. self weighted black base, with carry handle
- Modular system can be shaped to any layout
- Stable in windy conditions
- Quick and easy to install
- Anti-tamper linking system
 - difficult for unauthorized personnel to dismantle when linked
- Compact stacking lowers transportation costs
- Available in orange or white, with or without retroreflective sheeting

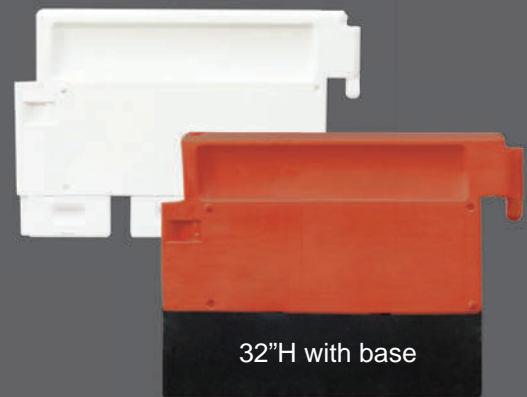

32"H with base

**STRONGWALL - LCD
Longitudinal Channelizing Device**



STRONGWALL BARRICADES



STRONGWALL ADA PEDESTRIAN BARRICADE

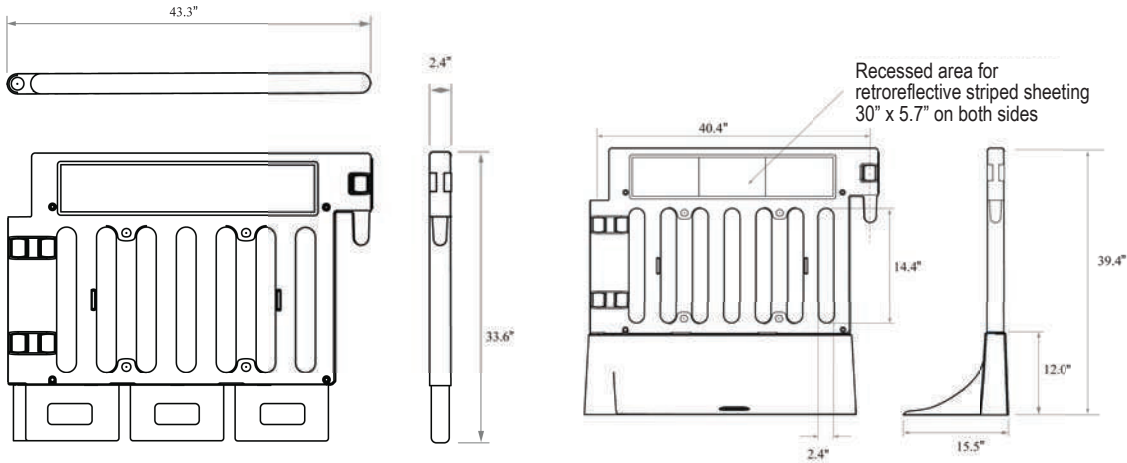

Specs

Composition	Polyethylene
Weight	40" H: 8 lbs., 51 lbs. w/base 32" H: 7 lbs., 50 lbs. w/base
Colors	Orange, White
Sheeting Area	6" x 30" on each side
Retroreflective Sheeting	Striped sheeting in engineer grade or high intensity prismatic grade
Base Dimensions	40.4" L 15.5" W 12" H
Base Weight	43 lbs.

STRONGWALL - LCD Longitudinal Channelizing Device

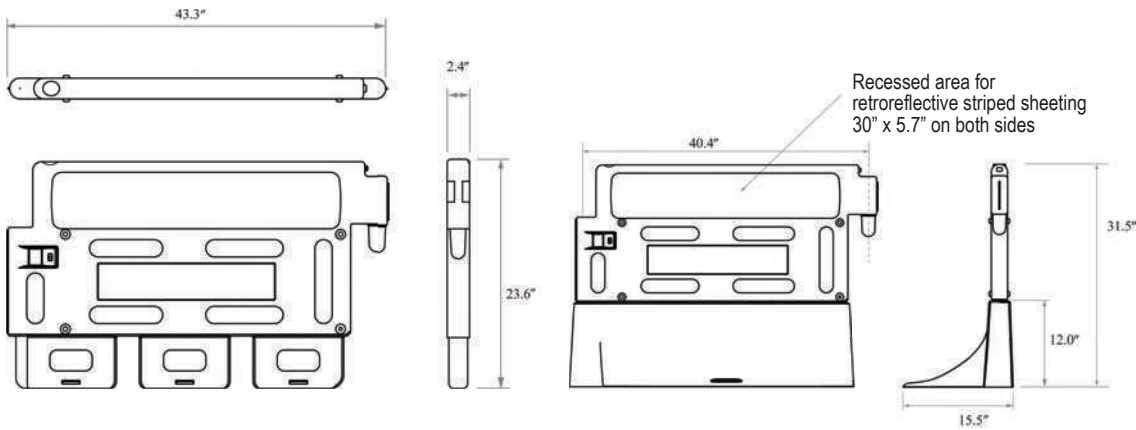

Compact Stacking

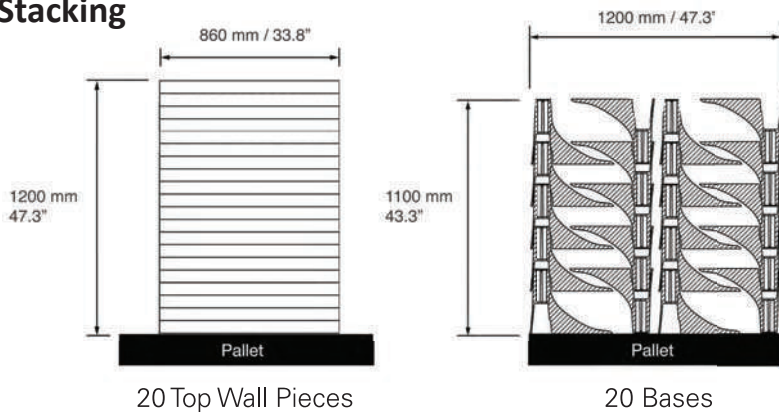

10700 Frankstown Rd
Pittsburgh, PA 15235
(866) 843-5193